

RELEASE

DATE:

COMPANY:

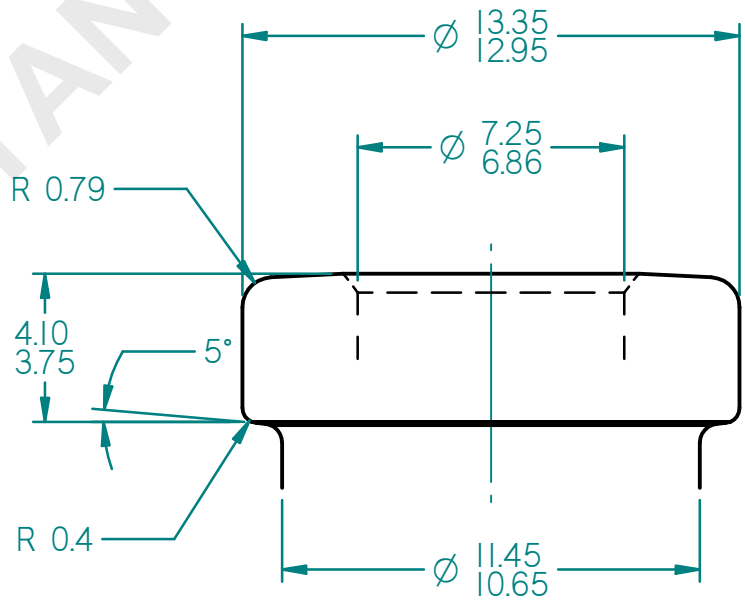
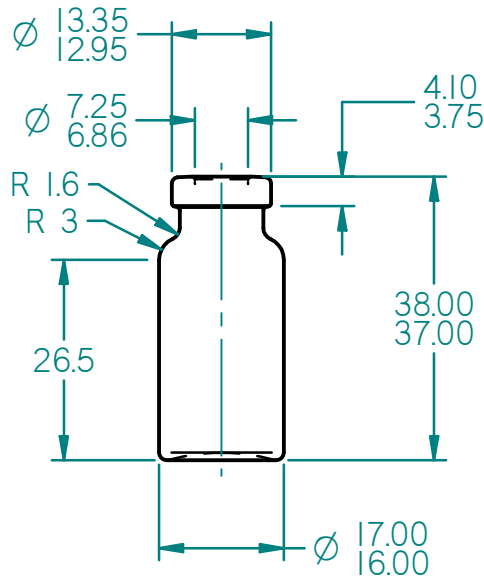

FINISH : 13 mm STD.

Protective note ISO 16016 observed

GENERAL TOLERANCES DIN 6129-1 (DIMENSIONS WITHOUT TOLERANCES ARE FOR REFERENCE ONLY)				FINISH: 13 mm STD.		O'FLOW CAPACITY: 3.70 - 4.30 ml		ARTICLE NO.: 5151190100			
				FINISH DWG: NA		WEIGHT: 7.5 g Approx					
				FINISH MOLD NO: 901		TYPE OF GLASS: I COLOUR: FLINT					
				DATE	NAME		TITLE: 3 mL METRO				
				DRAWN	20/11/2013 Paresh						
				CHECKED	20/11/2013 H.B.P.						
				SCALE	1 : 1, 5 : 1						
				GERRESHEIMER NEUTRAL GLASS & ALLIED INDS. PVT. LTD. MUMBAI / KOSAMBA		MOLD NO.:	DRAWING NO.:		REVISION	SHEET	FORMAT
						002	B 1190		0	1 OF 1	A4
REV.	CHANGE	DATE	NAME	FILE: 3 mL METRO.dft							